

**CLASS-XII**  
**MODEL PAPER-1 (Solved)**

---

**BIOLOGY (THEORY)**

**Times : 3 Hours**

**Maximum Marks : 70**

**General Instruction :**

1. All questions are compulsory.
2. This question paper consists of four sections A, B, C and D. Section A contains 8 questions of 1 mark each. Section B is of 10 questions of 2 marks each. Section C has 9 questions of 3 marks each, whereas section D is of 3 questions of 5 marks each.
3. There is no overall choice. However an internal choice has been provided in one question of 2 marks, one question of 3 marks and all the three questions of 5 marks weightage. A student has to attempt only one of the alternative in such questions.
4. Wherever necessary, the diagrams drawn should be neat and properly labelled.

**SECTION-A**

1. When does an oocyte complete oogenesis? When does oogenesis begin in a human female?
2. Which organisms are usually the pioneer species in a (i) Hydrarch and (ii) Xerarch succession?
3. Give an example to show how the same species can occupy more than one trophic level in the same ecosystem.
4. Cucurbits and coconut bear unisexual flowers but are monoecious. Why?
5. Define allelomorphs.
6. DNA in chromosomes also replicates semi-conservatively. How did Taylor and colleagues prove it?
7. Besides converting the milk to curd, which are the two other roles played by LAB?
8. What are baculoviruses?

## SECTION-B

9. (i) Very small animals like shrews and humming birds are rarely found in Polar Regions. Why?  
(ii) Define Diapause.
10. Read the graph given below and correlate the uterine events that take place according to the hormonal levels on
- (i) 6-15 days  
(ii) 16-25 days  
(iii) 26-28 days (if ovum is not fertilized)

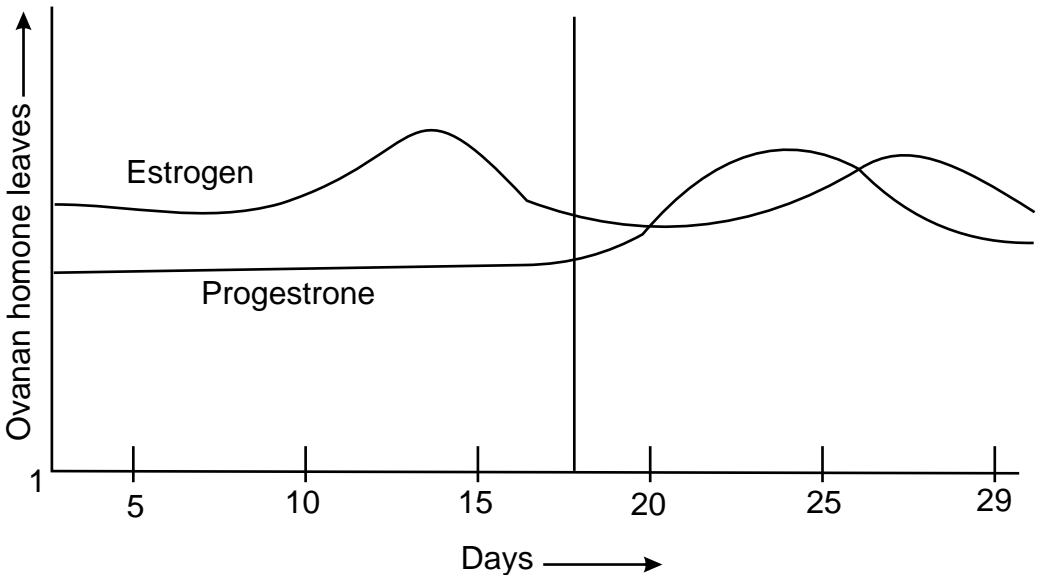

11. Draw the structure of initiator t-RNA molecule. Why is t-RNA called as an adapter molecule?

OR

Lactose plays a dual role in the lac-operon. How? Why is lac operon said to be under negative regulation?

12. (a) The graph below represents the growth patterns of two types of aquatic organisms over a brief period of time in a water body surrounded by an agricultural land extensively supplied with fertilisers. Identify the organisms that would represent (i) A and (ii) B.

- (b) State the reason for such a change in the water body and also write the term given to it.

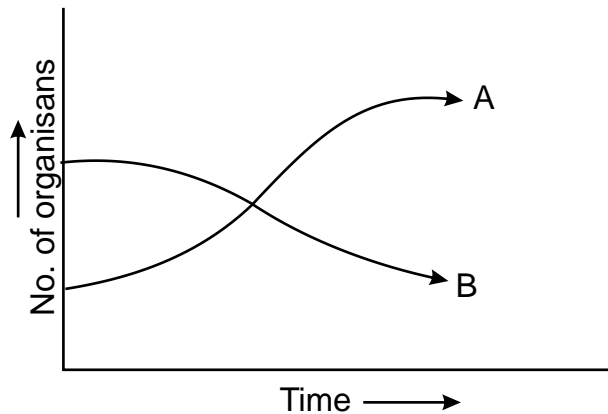

13. How do Cu 7 or Multiload 375 and Progestasert or LNG-20 differ in their contraceptive action?
14. Inbreeding is necessary and useful in some cases. How? Name the problem which can be caused due to close inbreeding and the way to get rid of the problem.
15.  $\alpha$ -Interferons are helpful in controlling a very fetal disease. Name the disease and ways to detect it. How do the  $\alpha$ -interferons help in such cases?
16. How is a divalent cation like Calcium useful in making the host cell competent for transformation with rDNA? What is biolistics?
17. Approval of which organization is needed for getting a clearance for mass production of a genetically modified organism? What can be the any two possible reasons for the need of such organization?
18. IgE antibodies are usually produced in response to certain substances. What are such substances called? What is the condition caused due to such substance and mention the cell and its chemical which causes such condition?

## SECTION-C

19. An ecologist wants to explore an area with a higher biodiversity. Suggest whether he/she should explore a tropical region or a temperate region? Why?
20. Million of gamete mother cells have been formed in the fetal ovary of a human female. Trace the events which will follow till the formation of mature female gamete (Ovum).
21. Explain with a suitable example the phenomenon of incomplete dominance.
22. Draw the schematic structure of a transcription unit. What is the convention in defining the two strands of DNA in such case? What will be the bases in the coding strand if template strand reads 3'-ATGCATGCATGCATGCATGC-5'
23. Using algebraic equations prove that the frequency of occurrence of alleles of a gene or a locus is fixed and remain same for generations in a given population. Who proposed this? What factors effect it?
24. Explain the working of Sewage treatment plants and define primary sludge, flocs and activated sludge.
25. With the help of a flow chart show the multiplication of a retrovirus which can cause a deficiency of immune system which is acquired during life time of an organism.
26. Write the missing steps in the following flowchart :

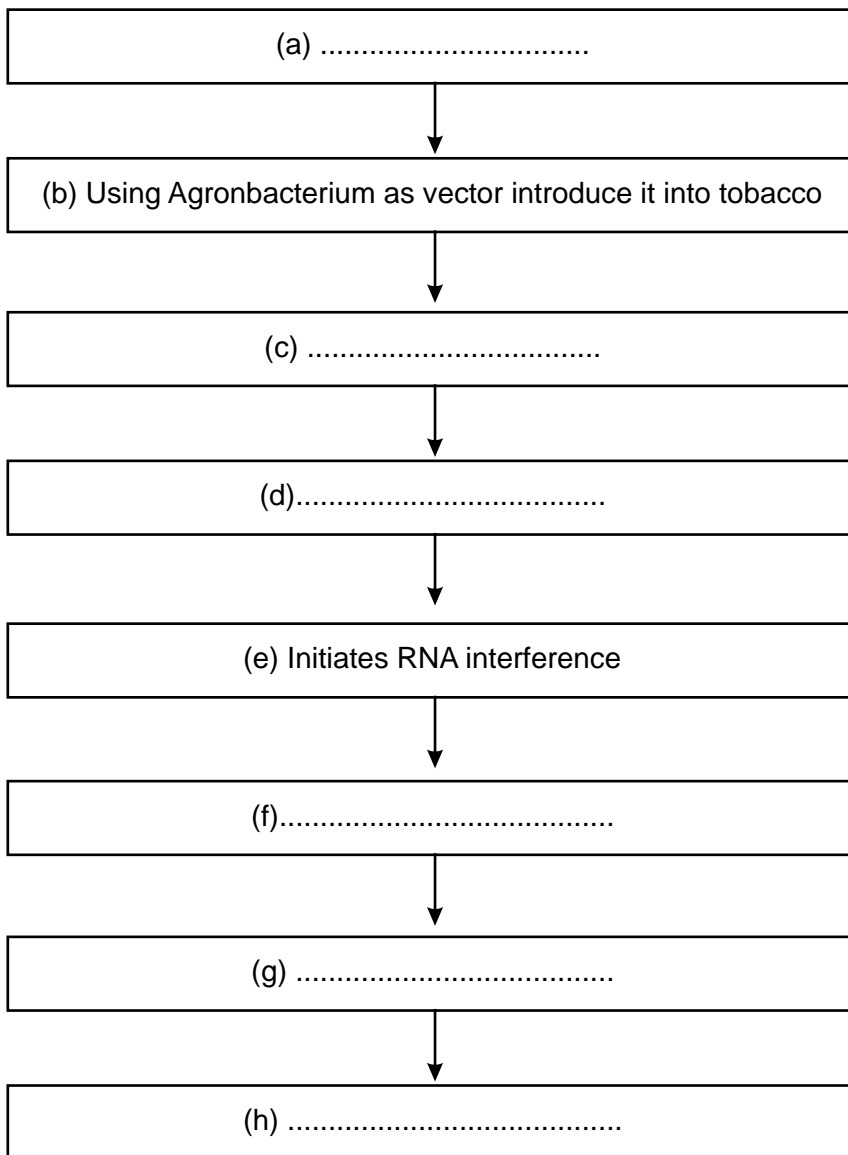

OR

What are the features of cloning vectors? How will you distinguish recombinants from non recombinants?

27. Explain with reference to PCR

- (a) A specific enzyme helps in amplification in PCR. Name the bacterium from which it is isolated and state how its thermostable nature is helpful.
- (b) Explain its use in molecular diagnosis

### SECTION-D

28. Domestic and sewage effluents can cause algal bloom, biomagnification, eutrophication. How? What effect does it have on BOD? What is cultural eutrophication?

OR

How is the "sixth episode of extinction" of species on earth, now currently in progress, different from the five earlier episodes? What is it due to? Explain the various causes that have brought about this difference.

29. (a) Explain the process of megasporogenesis.  
(b) Name any three outbreeding devices. What is self incompatibility?

OR

Show diagrammatically the stages of embryonic development from zygote upto implantation in humans.

30. (a) Show diagrammatically the results of dihybrid cross carried out by T.H. Morgan to show linkage.  
(b) What is pedigree analysis and its use? What will be the genotype of each of the individuals in the following pedigree chart :

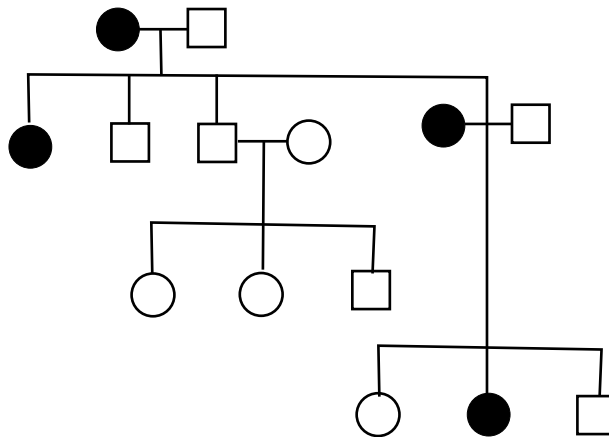

OR

- (a) Explain the technique in which VNTRs can be used in ascertaining the genetic diversities.  
(b) What are the differences between prokaryotic and eukaryotic transcription?

**CLASS-XII**  
**SAMPLE PAPER-1 (Solved)**  
**ANSWERS**

---

**SECTION-A**

1. Oogenesis completed when sperm comes in contact with zona pellucida of ovum. Oogenesis is initiated during embryonic development.
2. **Hydrarch Succession** : Usually small phytoplanktons.  
**Xerarch Succession** : Usually lichens.
3. Sparrow is primary consumer when eats seeds and secondary consumer when it eats worms.
4. They are Monoecious as both male and female flowers occur on same plant.
5. **Allelomorphs** : Various or slightly different forms of a gene having same position on chromosome.
6. Used radioactive thymidine on DNA of chromosomes in *Vicia faba*.
7. (i) Improves nutritional quality by increasing vitamin B12  
(ii) Check disease causing microbes.
8. **Baculoviruses** : Pathogens that attack insects and arthropods.

**SECTION-B**

9. They have large surface area relative to their volume so lose body heat very fast in colder regions. Hence, occur rarely in polar region.  
**Diapause** : A stage of suspended development shown by many zooplanktons in lakes and ponds.
10. (i) Regeneration of endometrium.  
(ii) Uterus gets high vascularised, ready for embryo implantation.  
(iii) Disintegration of endometrium.

11.

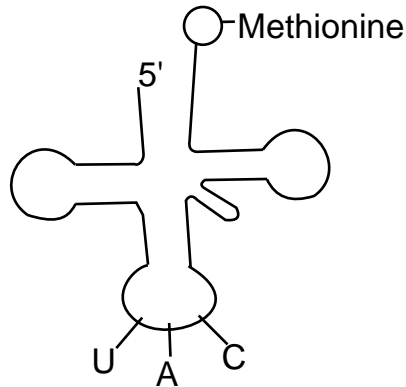

Adapter molecule because

- (i) on one hand reads the code,
- (ii) on the other hand binds to specific amino acid.

OR

Lactose plays as inducer as well as substrate in the lac-operon. Lac operon is under negative regulation as the presence of repressor prevents the transcription in the operon.

- 12. a
  - (i) Water hyacinth/algal growth
  - (ii) Fish/Aquatic animals.
- b
  - (i) Excessive growth of algae triggered by nitrates and phosphates from agricultural land run off water.
  - (ii) algal bloom/eutrophication

13. Cu7 and Multiload 375 → copper releasing IUD.s

Progestasert, LNG - 20 → hormone releasing IUD.s

Both increase phagocytosis of sperm and affect sperm motility. Hormone releasing also make uterus unsuitable for implantation and cervix hostile to the sperms.

14. Inbreeding

- (i) increases homozygosity, so helps in creating pure lines,
- (ii) exposes lethal genes.

**Problem Caused** : Inbreeding depression.

**Remedy** : Mating with unrelated superior animals of the same breed.

15. **Disease** : Cancer

**Ways to Detect** : Biopsy, MRI, Radiography, CT α-interferons activate immune system and helps in destroying the tumor.



16. Divalent cations increases efficiency with which DNA enters the bacterium through pores in its cell wall.

**Biolistics** : Bombarding the cells with high velocity micro particles of gold or tungsten coated DNA.

17. GEAC : Genetic Engineering Approval committee

- to check validity of GM research,
- to ensure safety of introducing GM organisms for public services.

18. IgE are produced against allergens. Condition is called allergy.

Mast cells cause the allergic response by secreting histamine and serotonin.

### SECTION-C

19. He should explore tropical region because tropical regions have higher diversity due to :

- (i) More speciations as remained undisturbed for millions of year.
- (ii) Less seasonal so more niche specialisation for species.
- (iii) More solar energy so more productivity.

20. Refer figure 3.8(b), NCERT-Bio text book class XII on page no. 49.

21. Refer Page 76 NCERT.Bio Text Book

22.

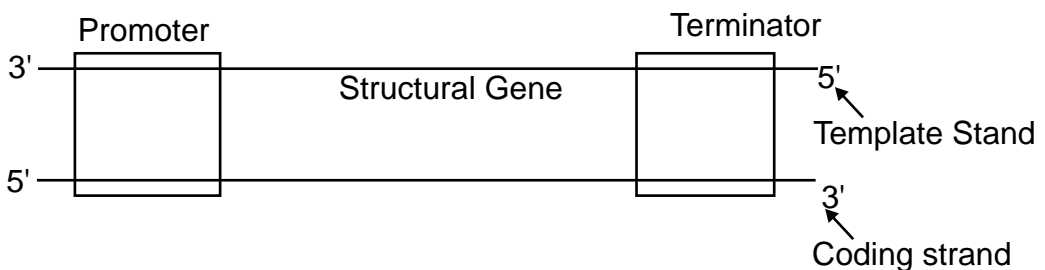

**Convention** : All reference point while defining a transcription unit is made with respect to coding strand. Promoter region is towards 5' end of coding strand. Coding Strand 5' TACGTACGTACGTACGTACG 3'

23. Sum total of all allelic frequencies is one.

Let p and q represent the frequency of alleles A and alleles .a. respectively.

The frequency of AA is  $p^2$  and .aa.is  $q^2$  and that of Aa is  $2pq$ .

Hence,  $p^2 + 2pq + q^2 = 1$

This is a binomial expansion of  $(p + q)^2$

i.e. it remains constant at 1.

❑ This was proposed by Hardy and Weinberg.

❑ Gene flow, genetic drift, mutation, genetic recombination and natural selection effect it.

24. Refer page 184, NCERT - Biology Class XII.

25. Refer fig 8.6, page 155, NCERT - Biology Class XII.

26. (a) Isolate nematode specific genes.

(b) Produces sense and anti sense RNA in host cells.

(c) Forms double stranded RNA (due to being complementary).

(d) Silence the specific mRNA of the nematode.

(e) Transgenic tobacco plant is protected against nematode.

❑ **Features of Cloning Vectors are:**

(a) Ori site    (b) Selectable marker    (c) Cloning sites.

❑ Recombinant and non-recombinants can be distinguished by using insertional inactivation method in which recombinant DNA is inserted in coding sequence of an enzyme  $\beta$ -galactosidase.

This results into inactivation of the enzyme. Presence of chromogenic substrate gives blue coloured colony if plasmid does not have an insert but no colour is produced if insert is there (as  $\beta$  galactosidase becomes inactivated).

27. (a) Taq polymerase obtained from bacterium called as *Thermus aquaticus*.

(b) Very low concentration of bacteria or virus can be detected by amplifications of their nucleic acid by PCR.

28. ❑ Refer page 276, NCERT - Class XII, Biology.

- ❑ It increases the BOD of water.
- ❑ Human activities have accelerated the rate of eutrophication. This is called cultural eutrophication.

OR

- ❑ Its occurring at a faster rate.
- ❑ Its due to human activities.
- ❑ Causes are
  - (i) Habitat loss and fragmentation
  - (ii) Over exploitation.
  - (iii) Alien species invasions.
  - (iv) Co-extinctions

Refer page 264, NCERT-Bio Class XII

29. ❑ Refer page 25-27, Class XII-NCERT (Biology).
- ❑ Three outbreeding devices
    - (a) Pollen release and stigma receptivity are not synchronised.
    - (b) Anther and stigma are placed at different position.
    - (c) Self-incompatibility. Genetic mechanism which prevents self pollen from fertilising the ovule by inhibiting pollen germination or pollen tube growth in the pistil.

OR

Refer Fig 3.11, page 52, NCERT-Biology Class XII.

30. (a) Refer Fig. 5.11. page 84-Biology Class XII
- (b) Analysis of traits in several of generations of a family is pedigree analysis.

Use : To trace inheritance of a specific trait, abnormality or diseases.

- (a) The process/technique is DNA fingerprinting (Refer page No. 122, NCERT-Biology Class XII).
- (b) Refer page No. 110-111, NCERT-Biology, Class XII.

